



Battery Specifications

COBRA SEALED MAINTENANCE FREE CALCIUM BATTERIES

PART NUMBER	Post Configuration	Terminal Type	CCA	L (MM)	W (MM)	H (MM)	WARRANTY PERIOD
SMALL CARS							
SMF NS40Z	A	SP	300	197	129	224	24 MTHS
SMF NS40ZL	B	SP	300	197	129	224	24 MTHS
SMF NS40ZS	A	STD	300	197	129	224	24 MTHS
SMF NS40ZLS	B	STD	300	197	129	224	24 MTHS
SMF N43	G	FDF	305	235	135	170	24 MTHS
SMF 55B24L	B	SP	430	238	134	225	24 MTHS
SMF 55B24R	A	SP	430	238	134	225	24 MTHS
SMF 55B24LS	B	STD	430	238	134	225	24 MTHS
SMF 55B24RS	A	STD	430	238	134	225	24 MTHS
MEDIUM/LARGE CARS							
SMF 22F-530	B	STD	530	240	174	205	24 MTHS
SMF 22FR-530 (LEFT HAND POS)	A	STD	530	240	174	205	24 MTHS
SMF 22F-530DF	B	FDF	530	240	174	211	24 MTHS
SMF AU22R-530 (LEFT HAND POS)	A	STD	530	231	169	205	24 MTHS
SMF AU22-530DF	B	SDF	530	231	169	211	24 MTHS
SMF 86-550	A	STD	550	245	175	206	24 MTHS
SMF 86R-550 (RIGHT HAND POS)	B	STD	550	245	175	206	24 MTHS
SMF 55D23L	B	STD	500	232	173	225	24 MTHS
SMF 55D23R	A	STD	500	232	173	225	24 MTHS
SMF 80D26L	B	STD	600	260	174	225	24 MTHS
SMF 80D26R	A	STD	600	260	174	225	24 MTHS
EUROPEAN/AMERICAN CARS							
SMF 54316 (DIN 44)	B	STD	420	211	175	175	24 MTHS
SMF 55457 (DIN 55)	B	STD	500	245	175	175	24 MTHS
SMF 55458 (DIN 55L)	A	STD	500	245	175	175	24 MTHS
SMF 56318 (DIN 66)	B	STD	580	280	175	175	24 MTHS
SMF 56640 (DIN 66L)	A	STD	580	280	175	190	24 MTHS
SMF 56638 (VE)	B	STD	580	280	175	190	24 MTHS
SMF 58014 (DIN 77)	B	STD	710	315	175	175	24 MTHS
SMF 58515 (DIN 88)	B	STD	740	353	175	175	24 MTHS
SMF 58-530	A	STD	530	236	183	177	24 MTHS
SMF 58R-530	B	STD	530	236	183	177	24 MTHS
SMF 65-730	A	STD	730	292	189	191	24 MTHS
SMF 65-820	A	STD	820	292	189	191	24 MTHS
SMF 75-660	A	FSP	660	231	179	185	24 MTHS
SMF 78-660	A	FSP	660	260	179	185	24 MTHS

PART NUMBER	Post Configuration	Terminal Type	CCA	L (MM)	W (MM)	H (MM)	WARRANTY PERIOD
COMMERCIAL VEHICLES							
SMF U1R-290 (12 N 24-3)	B	STD	290	186	126	181	12 MTHS
SMF U1-290 (12 N 24-4)	A	STD	290	186	126	181	12 MTHS
SMF NX120-7 (N70ZZ)	A	STD	730	304	173	225	12 MTHS
SMF NX120-7L (N70ZZL) L)	B	STD	730	304	173	225	12 MTHS
SMF 31-930 A	E	STD	930	330	173	240	12 MTHS
SMF 31-930 S (THREADED D POST)	E	TP	930	330	173	240	12 MTHS
SMF N100	A	STD	740	408	175	211	12 MTHS
SMF N120	D	STD	820	505	183	240	12 MTHS
SMF N150	D	STD	1000	508	222	241	12 MTHS
SMF 68032 (N94B)	C	STD	1100	513	222	220	12 MTHS
SMF N200	D	STD	1150	523	279	250	12 MTHS

DEEP CYCLE / STARTING RV							
SMF RV24-600 (82 A/H)	I	DP	600	260	174	225	12 MTHS
SMF RV27-730 (105 A/H)	I	DP	730	304	173	225	12 MTHS
SMF RV27R-730 (105 A/H)	H	DP	730	304	173	225	12 MTHS
SMF RV31-830 (120 A/H)	J	DCP	830	330	174	240	12 MTHS

■ Warranty Periods Taxi Use 6 Months / Commercial Use 12 Months when battery used in correct sizes / application

Post Configuration

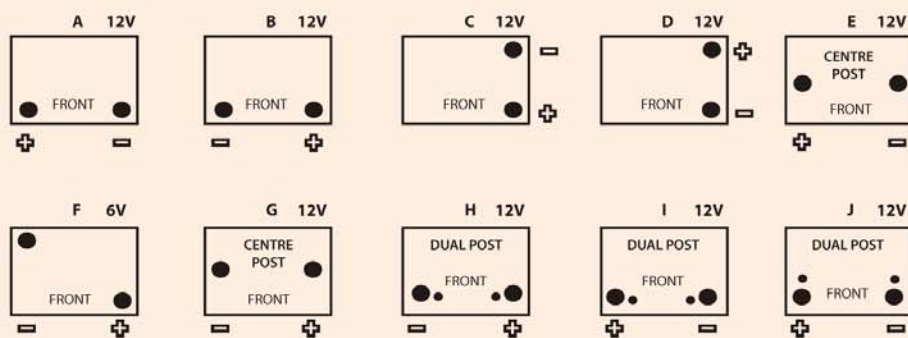

Abbreviation:	
DP	Dual Post
DCP	Dual Centre Post
FDF	Front Dual Fit
FSP	Front Screwed Post
SDF	Side Dual Fit
SP	Small Post
STD	Standard Post
TP	Threaded Post

■ Battery Specifications are to be used as a guide only all specifications are subject to change without further notice

■ Please note during 2011, all the SMF 22F/AU22 Series will be upgraded to 550 CCA and all the SMF 86/86R Series will be upgraded to 600 CCA, all dimensions will remain the same but the CCA capacity will be increased. For example, new part numbers will be as follows:
SMF 22FR-530 upgrades to SMF 22FR-550
SMF 86-550 upgrades to SMF 86-600 and so on.